

DETTAGLIO C
SCALA 1:2

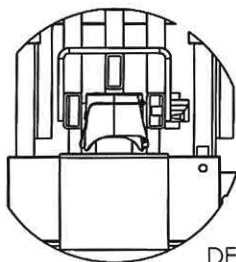
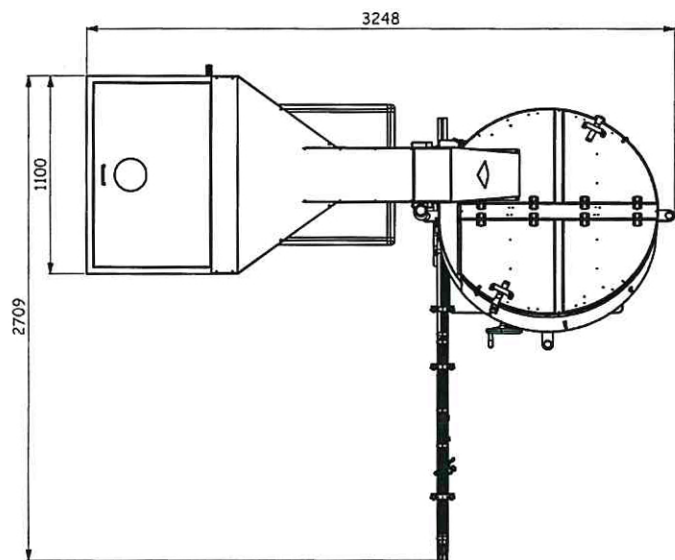

DETTAGLIO B
SCALA 1:2

Peso: 645.71 Kg

5	.Elevatore 500 H2250F2	1	14619-ENF500H225	.
4	Assieme colonnine NA60	1	14619-800	.
3	Canale aria tappo	1	14619-300	.
2	STM120GT DX	1	14619-STM-120D	.
1	Banchetto regolabile	1	14619-100	.

Pos.	Descrizione	Q.tà	Num. parte/codice	Materiale
------	-------------	------	-------------------	-----------

 SARG srl Tecnologie dell'orientamento		Descrizione: Alimentazione tasti attuatori Materiale: . Smussare gli spigoli 0,5x45°		Tolleranze generali ISO 2768	
Trattamento: .			Form.: A2	Data: 04/03/2015	
Commissa: 14619		Dis.:	Visto: .	Appr.: .	Scala: 1:20
Cliente:		N° disegno: 14619-000		Foglio 1 di 1	

Proprietà della SARG srl - è vietata la riproduzione e comunicazione a terzi senza autorizzazione scritta. La società tutela i propri diritti a norma di legge.

